

PIEZORESISTIVE OEM PRESSURE TRANSDUCERS

ABSOLUTE- AND GAUGE PRESSURE

The Series 7S / 9S is the latest development in media isolated piezoresistive silicon chip pressure transducers. The new low mass one-piece housing is smaller with a brazed stainless steel diaphragm for lower production cost, giving excellent long-term stability combined with easy installation.

The Series 7S / 9S can be installed into a housing using an O-ring seal, or it can be welded. Welding should only be made to the flange at the rear of the transducer. Performance specifications will remain unaffected by the proper installation. The O-ring seal may be fitted directly below the flange, or as a peripheral seal at the front face of the transducer. The rear flange can be modified or machined off completely where space is important.

The thin flange and outer capsule wall ensure that mechanical mounting stresses are not transmitted into the measuring cell. The structure also has good thermal conductance and the sensor closely tracks the process media temperature.

The Series 7S / 9S transducers are constructed from 316L stainless steel, using a high temperature hydrogen brazing technique; the brazed 316L diaphragms are highly resistant to corrosion. The diaphragm of the Series 9 FL is laser welded with the housing. Electrical connection is made via a five-pin header. Leadout wires, or a PCB, can be soldered directly to the header pins. Series 7SE / 9SE versions are supplied with PCB fitted.

Every pressure transducer is subjected to comprehensive tests for pressure and temperature characteristics, and is delivered with an individual calibration certificate (except for version 9 SE / 9 FLE). Special testing is available on request from the customer.

Typical applications are, heating pumps, autoclaves and dialysers. Other applications include measurement of altitude, avionics, meteorology, servo controls, robotics, hydraulics, hygienic and pharmaceutical engineering, drift mining, injectors, and many more.



Series 7 S



Series 9 S
(< 50 bar)



Series 9 FL
(< 50 bar)



Series 9 FL
(≥ 50 bar)

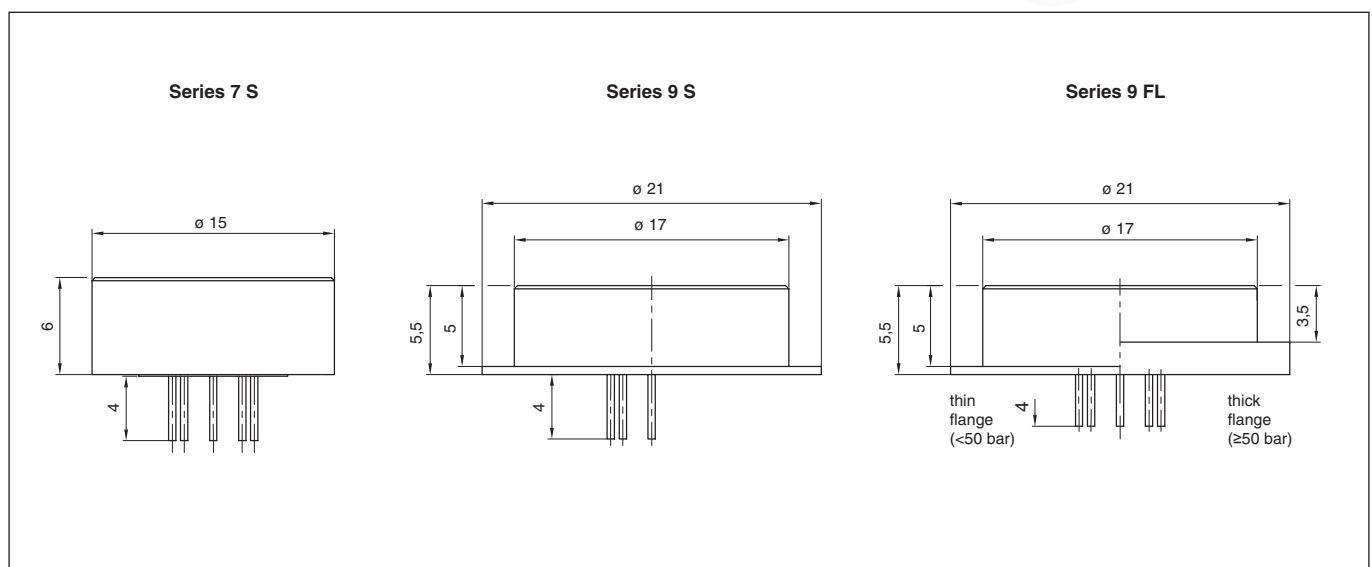

Subject to alterations

11/08

KELLER AG für Druckmesstechnik
KELLER Ges. für Druckmesstechnik mbH

St. Gallerstrasse 119
Schwarzwaldstrasse 17

CH-8404 Winterthur
D-79798 Jestetten

Tel. +41 (0)52 - 235 25 25
Tel. +49 (0)7745 - 9214 - 0

Fax +41 (0)52 - 235 25 00
Fax +49 (0)7745 - 9214 - 60



KELLER

Specifications

Excitation I = 1 mA

Pressure Ranges (FS) and Overpressure in Bar. Signal Output in mV.

	-1	-0,5	-0,2	-0,1	0,1	0,2	0,5	1	2	5	10	20	
PR-7 S / 9 S (7 S: only from 5 bar)													
PAA-7 S / 9 S (7 S: only from 5 bar)					0,1	0,2	0,5	1	2	5	10	20	
PA/PAA/PR 9 FL (thin flange)					0,1	0,2	0,5	1	2	5	10	20	
PA-7 S / 9 S (7 S: only from 5 bar)								1	2	5	10	20	
PA-9 FL (thick flange)													50 100 200
Signal Output typ. * (mV)	75	50	25	15	15	30	60	100	140	200	225	225	225 225 225
Overpressure (bar)	-1	-1	-1	-1	2,5	2,5	2,5	3	4	7	15	30	100 200 300

PR: Vented Gauge. Zero at atmospheric pressure PAA: Absolute. Zero at vacuum PA: Sealed Gauge. Zero at atmospheric pressure (at calibration day) * ± 40%

Bridge Resistance @ 25 °C	Ω	3500	± 20%
Constant Current Supply	mA	1 nominal	5 max.
Insulation @ 500 VCC	MΩ	100	

Operating Temperature	°C	-30...100
Compensated Range	°C	-10...80 ⁽¹⁾
Storage Temperature	°C	-40...100
Vibration (20 to 5'000 Hz)	g	20
Endurance (FS @ 25 °C)	Cycles	> 100 x 10 ⁶ FS

Housing and Diaphragm	Stainless Steel, Type 316 L
Brazing Material (7 S / 9 S)	Nickel / Chrome / Palladium
Oil Filling	Silicone Oil ⁽¹⁾
Weight	7 S: 4,5 g 9 S: 6,5 g 9 FL: 6,6 g 9 FL (thick flange): 8,2 g
Dead Volume Change @ 25 °C	< 0,1 mm ³ / FS

Accuracy ⁽²⁾	%FS	0,5 typ. ⁽¹⁾ 1 max.
Offset at 25 °C	mV	< 5 mV (compensatable with R5 ⁽³⁾)
Temperature Error		-10...80 °C ⁽¹⁾
- Zero	mV / °C	< 0,05
- Sensitivity	% / °C	< 0,03
Long Term Stability typ.	mV	0,75
Time Constant	ms	< 1 (Resonance > 30 kHz)

Electrical Connections

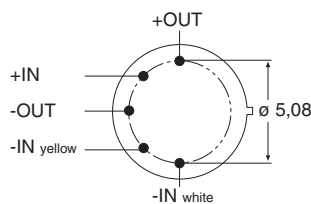

⁽¹⁾ Others on request.

⁽²⁾ Including linearity, hysteresis and repeatability. Linearity calculated as best straight line through zero.
Note: Generally, accuracy and overload is improved by factor of 2 to 4 if the sensor is used in the range of 0...50 %FS

⁽³⁾ External compensation, potentiometer not supplied.

Option: Sensor with Electronics Series 9 SE, Series 9 FLE

Print:	Ø 15 mm
Ranges:	from 0,5 bar
Output:	4...20 mA, 0...10 V, 0,5...4,5 V ratiom. 0...100 mV
Supply:	8...28 V, 13...28 V, 5 V / 10 VDC
Total Error Band:	max. 1,0 %FS (0...50 °C), max. 1,5 %FS (-10...80 °C)

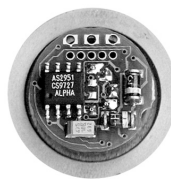

PR-9S/20 BAR/80507.8 ⁽¹⁾					143 ⁽²⁾
⁽³⁾ Temp [°C]	⁽⁴⁾ Zero [mV]	⁽⁵⁾ +510 [mV]	⁽⁶⁾ Comp [mV]	⁽⁷⁾ dZero [mV]	09/15
-10.0	-15.0	-20.2	0.2	-0.5	
-0.2	-14.6	-19.9	0.4	-0.3	
24.6	-13.8	-19.7	0.7	0.0	
49.7	-13.2	-19.8	0.6	-0.1	
79.4	-12.4	-20.1	0.3	-0.4	
COMP	R1 = 510 kOhm ⁽⁸⁾	R4 = 82.0 Ohm ⁽⁸⁾			
ZERO	0.7 mV ⁽⁹⁾				
SENS	9.23 mV/bar at 1.000 mA ⁽¹⁰⁾				
SENS	36.93 mV/bar at 4.000 mA				
LIN	⁽¹³⁾ [bar]	⁽¹⁴⁾ [mV]	⁽¹¹⁾ Lnorm [%Fs]	⁽¹²⁾ Lbfs [%Fs]	
	-0.000	0.0	0.00	-0.17	
	10.000	92.7	0.22	0.17	
	20.000	184.2	-0.22	-0.17	
Long Term Stability Ok ⁽¹⁵⁾					
Lot 7.0415.00 ⁽¹⁶⁾					
Test 500 Volt ok ⁽¹⁷⁾					
Supply 1.000 mA ⁽¹⁸⁾					
12.08.08 ⁽¹⁹⁾ ----- GOL3.I03CaK ⁽¹⁹⁾					

Each sensor is delivered with a calibration sheet with the following data:

- Type (PR-9S), drawing-no. (80507.8) and range (20 bar) of sensor
- Test location-no. resp. serial-no. (engraved on request) of sensor
- Test temperatures
- Uncompensated zero offset in mV
- Zero offset values, in mV, with test resistance (510 kΩ) (for factory computation only)
- Zero offset, in mV, with calculated compensation resistor R1 or R2
- Temp. zero error, in mV, with compensation resistor R1 or R2
- Compensation resistor values R1 / R2 and R3 / R4
- Offset with compensation resistors R1 / R2 and R3 / R4 fitted. (fine adjustment of zero with R5 potentiometer)
- Sensitivity of pressure sensor
- Linearity (best straight line through zero)
- Linearity (best straight line)
- Pressure test points
- Signal at pressure test points
- Results of long term stability
- Lot-type (on request, identification of silicon chip)
- Voltage insulation test
- Excitation (constant current)
- Date of test ----- Test equipment

Remarks:

- The indicated specifications only apply for constant current supply; the sensor should be excited between 0.5 and 4 mA. The sensor signal is proportional to the current. When exciting with constant voltage, the zero offset values remain the same, the sensitivity decreases approx. 1% per +5 °C.
- If exposed to extreme temperatures, the compensation resistors should have a temperature coefficient of < 50 ppm/°C. Sensor and resistors can be exposed to different temperatures.
- The sensors may be ordered with integrated compensation resistors.

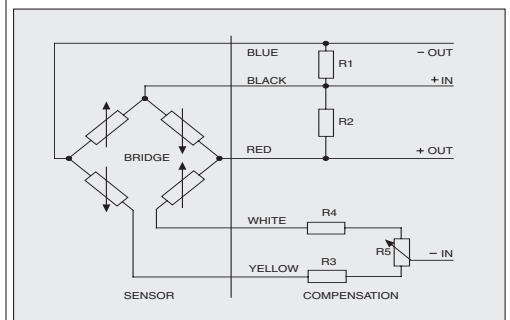

Subject to alterations

11/08

KELLER AG für Druckmesstechnik
KELLER Ges. für Druckmesstechnik mbH

St. Gallerstrasse 119
Schwarzwaldstrasse 17

CH-8404 Winterthur
D-79798 Jestetten

Tel. +41 (0)52 - 235 25 25
Tel. +49 (0)7745 - 9214 - 0

Fax +41 (0)52 - 235 25 00
Fax +49 (0)7745 - 9214 - 80